

*Makita*<sup>®</sup>













# GARDEN CATALOGUE

APRIL 2024



# SYMBOL KEY / CONTENT

## Garden Products

	110V
	240V
	Electronic ignition
	Variable speed trigger
	Soft start
	Electronic brake
	Inertia brake
	Automatic chain brake
	Anti-Vibration system
	Tool-less blade change
	Decompressor
	4 stroke
	Double insulated

## New Products

4

Cordless Garden Products	XGT	LXT	CXT
Chainsaws	A6	A16	-
Earth Auger	A7	A22	-
Split-Shaft	A9	A23	-
Brush Cutters	A9	A18	-
Linetrimmers	A10	A18	-
Blowers	A12	A24	-
Hedge Trimmers	A13	A26	A29
Pruning Saw	-	A29	A30
Pruning Shears	-	A30	A31
Sprayers	-	A31	A31
Grass Shears	-	A34	A34
Wheelbarrow	-	A32	-
Lawn Mowers	A14	A35	-

## Petrol / Electric Garden Products

Chainsaws	A42
Linetrimmers	A42
Hedge Trimmers	A43
Lawn Mowers	A43
Scarifiers	A45
Shredder	A45

**1**  
Year  
Guarantee

Every Makita Tool is thoroughly inspected and tested before leaving the factory and is guaranteed to be free of defects from workmanship and materials for the period of ONE YEAR from the date of original purchase. Should any trouble develop during this one year period, return the COMPLETE tool freight prepaid, to EITHER an Authorised Makita Service Agent or to Makita (UK) Ltd. If inspection shows the trouble is caused by defective workmanship or material, Makita will repair WITHOUT CHARGE.

### This guarantee does not apply where:

- Repairs have been made or attempted by others.
- Repairs are required because of normal wear and tear.
- The tool has been abused, misused or improperly maintained.
- Alterations have been made to the tool.
- This guarantee does not affect your statutory rights.



[makitauk.com](http://makitauk.com) for the latest noise and vibration figures

Makita (UK) Ltd, Michigan Drive, Tongwell, Milton Keynes, Bucks, MK15 8JD Tel: 01908 211678



Makita Corporation is a member of  
The European Power Tool Association.

All machines in this catalogue conform to CE Marking Regulations.  
All weights quoted in this catalogue conform to EPTA procedure 01.  
All vibration figures conform to the relevant EN standard.

VAT calculated at 20% subject to change.  
Accessories shown are not necessarily supplied as standard equipment.  
Prices and specification shown may change owing to our policy of constant improvement.  
Subject to availability. E&OE.

# PDC1200

(see page 7 for details)

With integrated battery cells

**XCUT** **40Vmax** **LXT 36V** **CONNECTX**  
18V • 18V



33.5Ah



1,200Wh



1.1m

# PDC01

(see page 7 for details)

Use with 4x 18V batteries

**LXT 36V** **18V** **CONNECTX**  
18V • 18V



12 - 24Ah



432Wh



1.7m

**CONNECTX**

Direct Connection



**XCUT** **40Vmax**

191N62-4



**LXT 36V**

18V • 18V

191J51-5



**18V** **LXT 36V**

191J50-7



# WHY CHOOSE XGT

Through Makita's innovative engineering, the technology within the XGT system will create the equipment and tools of the future. Tools equivalent to petrol or mains power with zero emissions and no trailing cables, XGT is safer and better for the environment.

Digital communication between battery and charger, and battery and tool - reduces charge times and protects batteries and tools from damage prolonging their life.



**XGT 80V**  
40Vmax + 40Vmax



**XGT 40Vmax**



# 120+ PRODUCTS ONE SYSTEM



## POWER



### PURE COPPER WIRE

Makita® XGT® Products feature purpose-built brushless motors with more copper windings for increased power output.

### RARE EARTH MAGNETS

Rare earth magnets of the highest quality are engineered within the brushless motors to maximise power and performance.

## SMART



### BUILT-IN MICROCHIPS

Built-in microchips in both tool and battery allow for real-time digital communication, actively monitoring heat, overload, and over-discharge.

### DIGITAL COMMUNICATION

Digital communication between XGT® Tools and Batteries through enhanced digital communication technology optimise performance to deliver up to 2X longer sustained power during demanding applications.

## TOUGH



### IMPACT ABSORBENT STRUCTURE

Durable outer casing and cell holder create space within the battery to absorb impact.

### WATER & DUST RESISTANCE

Water and dust-resistant triple layer structure and an enhanced terminal structure are engineered to protect against water and dust for any job site condition.

## RAPID



### MULTI-LAYER SURFACE CONTACTS

Multi-layer surface contacts within tool and battery are designed to take on high current demands.

### RAPID OPTIMUM CHARGING SYSTEM

XGT® Charger and Dual Cooling Fans digitally communicate before and during the charging process, evaluating battery condition to deliver a consistent fast charge. Charges LXT® batteries with adapter.

# WHAT IS XGT

XGT is a system with its own tools, batteries, and chargers. A combination of innovative tool design and higher output batteries provide a genuine solution for high demand industrial users.



## DIGITAL COMMUNICATION

Tool ◀▶ Battery ▶▶ Battery Charger

### TERMINAL SHORT-CIRCUIT PREVENTION STRUCTURE

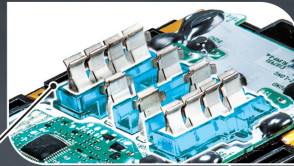

WALL

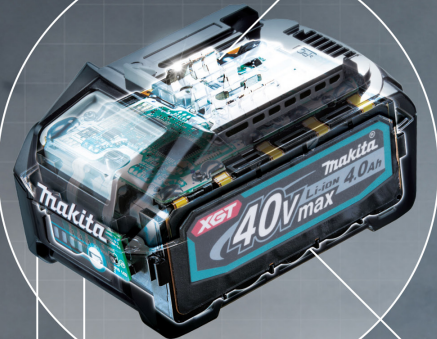

4-LED FUEL GAUGE INDICATOR

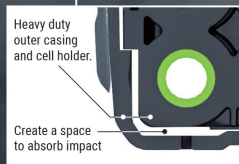

SHOCK ABSORPTION

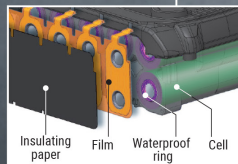

WATERPROOF TRIPLE-LAYER

## OPTIMUM POWER SUPPLY AND CHARGING SYSTEM

The XGT range of tools and batteries come with a built-in program, providing digital communication between the battery and tool. Allowing not only for the battery to talk with tool but also the tool to talk to the battery. A battery technology and motor that work together for optimum performance.

## RAPID CHARGING SYSTEM

The charger will cool down the battery before charging if the battery temperature is high. Built-in fan circulates air through the battery before charging and during to cool the battery for a faster charge time.

### THE OPTIMUM CHARGING SYSTEM

Forced air cooling



Fast charging



### GENERAL CHARGING METHOD

Natural heat dissipation



Waiting time for charging



### The optimum charging system

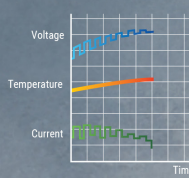

### General charging method

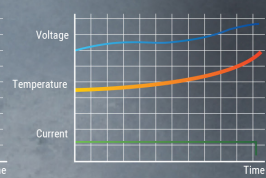

## OPTIMUM CHARGING SYSTEM

Auto maintenance system with two cooling fans to provide faster charging

## DIGITAL COMMUNICATION

The Makita Rapid Optimum Charger communicates with the battery's built-in chip throughout the charging process to optimise battery life by actively controlling current, voltage and temperature.

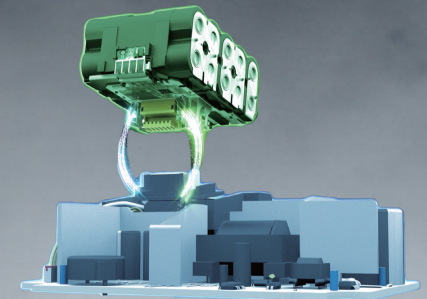

### Anytime Charge

No Memory Effect  
No Discharging Required



### Shock Absorbing

Heavy Duty Pack

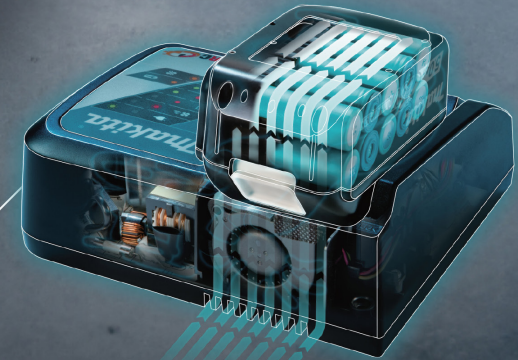

## BATTERY PROTECTION FUNCTION

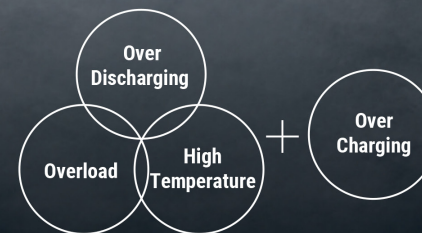

### COMMUNICATION

This communication technology allows the tool and battery to monitor conditions and exchange data in real time to protect against Overload, Over-Discharge and Overheating.

### CONNECTION

Multi-contact terminals reduce electrical resistance and increase connection stability withstanding against vibration, and ultimately ensures a stable current supply to the tool.

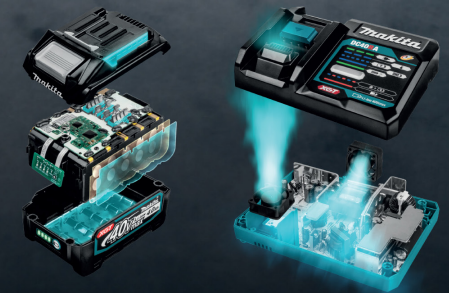

## 40V Max XGT Brushless Chainsaw

UC011G

Max Output	1,600 W
Bar Length	350 mm
Chain Type	80TXL
Chain Pitch	0.325"
Chain Gauge	0.043"
Chain Speed	0 – 25.5 m/s
Oil Tank Capacity	260 ml
Net Weight	6.1 – 7.4 Kg



### Model Versions

UC011GT201 2x 5.0Ah

UC011GZ Body Only

STANDARD EQUIPMENT: Fast charger, battery cartridges, guide bar, oil supply, chain cover, saw chain, wrench

## 40V Max XGT Brushless Chainsaw

UC014G/  
015G/016G

Max Output	1,600 W	Chain Pitch	0.325"
Bar Length	UC014G: 300 mm	Chain Gauge	0.043"
	UC015G: 350 mm	Chain Speed	0 – 25.5 m/s
	UC016G: 400 mm	Oil Tank Capacity	260 ml
Chain Type	80TXL	Net Weight	6.2 – 7.5 Kg



### Model Versions

UC014GT201 2x 5.0Ah

UC014GZ Body Only

UC015GT201 2x 5.0Ah

UC015GZ Body Only

UC016GT201 2x 5.0Ah

UC016GZ Body Only

STANDARD EQUIPMENT: Fast charger, battery cartridges, guide bar, oil supply, chain cover, saw chain, wrench

## 40V Max XGT Brushless Top Handle Chainsaw

UC006G

Max Output	1,400 W
Bar Length	250 mm
Chain Type	25AP-60
Chain Pitch	1/4"
Chain Gauge	0.050"
Chain Speed	0 – 24.8 m/s
Oil Tank Capacity	200 ml
Net Weight	3.8 – 4.7 Kg

**TO BE USED BY TRAINED TREE SURGEONS ONLY**



### Model Versions

UC006GZ Body Only

STANDARD EQUIPMENT: Guide bar, saw chain, wrench, oil supply

## 40V Max XGT Brushless Top Handle Chainsaw

UC002G  
UC003G

Max Output	1,400 W
Bar Length	250mm (UC002G) 300 mm (UC003G)
Chain Type	90PX
Chain Pitch	3/8"
Chain Gauge	0.043"
Chain Speed	0 – 24.8 m/s
Oil Tank Capacity	200 ml
Net Weight	3.8 – 4.7 Kg

**TO BE USED BY TRAINED TREE SURGEONS ONLY**



### Model Versions

UC002GD202 2x 2.5Ah

UC002GZ Body Only

UC003GD202 2x 2.5Ah

UC003GZ Body Only

STANDARD EQUIPMENT: Fast charger, battery cartridges, guide bar, saw chain, wrench, oil supply

## 40V Max XGT Brushless Telescopic Pole Saw

UA004G

Max output Power	1,500 W
No Load chain speed	0-20 m/s
Bar length	300 mm
Chain type	91PX
Chain Pitch	3/8"
Chain Gauge	0.050"
Oil tank capacity	160ml
Net weight	7.8 – 9.1kg



**OVERALL LENGTH (EXCL. CHAIN BAR) 2.6 - 3.8 METERS, TELESCOPIC RANGE 0 - 1.2 METERS**



### Model Versions

UA004GD203 2x 2.5Ah

UA004GZ Body Only

STANDARD EQUIPMENT: Fast charger, battery cartridges, saw chain, wrench, hex wrench, band assembly, guide bar, chain cover, round file, oil supply, lubricant



## 40V Max XGT Brushless Top Handle Chainsaw

UC006G

Max Output	1,400 W
Bar Length	250 mm
Chain Type	25AP-60
Chain Pitch	1/4"
Chain Gauge	0.050"
Chain Speed	0 – 24.8 m/s
Oil Tank Capacity	200 ml
Net Weight	3.8 – 4.7 Kg

**TO BE USED BY TRAINED TREE SURGEONS ONLY**



### Model Versions

UC006GZ Body Only

STANDARD EQUIPMENT: Guide bar, saw chain, wrench, oil supply

## 40V Max XGT Brushless Earth Auger

DG001G

No Load Speed (High)	0-1, 500 rpm
No Load Speed (Low)	0 – 400 rpm
Chuck Capacity	2 – 13mm
Max Drilling Capacity	200mm
Capacity (High resistance soil)	150mm
Capacity (Low resistance soil)	200mm
Max Torque (H/L)	55 / 136Nm
Net Weight	7.2 – 8.1Kg

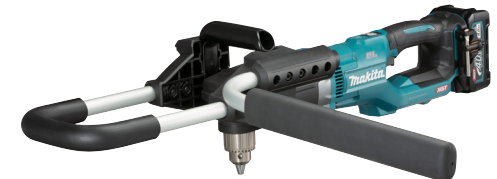

### Model Versions

DG001GD202 2x 2.5Ah

DG001GZ05 Body Only

STANDARD EQUIPMENT: Fast charger, battery cartridges, chuck key, hex wrench, adaptor x2.

# GET 80V MAX POWER FROM YOUR 40V MAX BATTERIES

Utilise your 40V Max batteries to get more power and run time from our 80V Max machines. The powerful 80V motor is powered by two 40V Max batteries in either 2.5Ah, 4.0Ah, 5.0Ah or 8.0Ah capacities.

XGT is a genuine solution for high demand industrial applications. A combination of innovative tool design and higher output batteries, providing a genuine solution for high demand industrial users as well.

The tough XGT construction design is supported by a charging system that charges batteries in as little as 28 minutes.

**XGT 80V**  
40Vmax + 40Vmax



## 40V Max XGT Brushless Split-Shaft

UX01G

No Load Speed (Hi)	0 - 9,700 rpm
No Load Speed (Med)	0 - 8,200 rpm
No Load Speed (Lo)	0 - 5,700 rpm
Max Output	1,000W
Net Weight	4.2 - 12.6kg

See page A23 for attachments



### Model Versions

UX01GD202 2x 2.5Ah

UX01GZ Body Only

STANDARD EQUIPMENT: Fast charger, battery cartridges, shoulder strap, hex wrench, accessory bag.



## 40V Max x2 (80V Max) XGT Brushless Brush Cutter

UR012G

Max output	2,000W
Speed Settings	3 speed + ADT mode
No Load Speed (L/M/H)	0 - 3,500 / 5,000 / 6,400 rpm
Spindle Size	M10 x 1.25 L
Cutting Diameter	480mm
Net Weight	8.0 - 9.3kg



### Model Versions

UR012GT203 2x 5.0Ah

UR012GZ04 Body Only

STANDARD EQUIPMENT: Nylon cutting head, hex wrench x2, box wrench, shoulder belt, accessory bag, fast charger, battery cartridges.



## 40V Max XGT Brushless Brush Cutter

UR013G

Max output	1,500W	<b>ANTI-RESTART FUNCTION</b>
No Load Speed	3,500 - 6,700rpm	
Spindle Size	M10 x 1.25L	
Cutting Diameter	450mm	
Net Weight	5.9 - 7.2Kg	



### Model Versions

UR013GT206 2x 5.0Ah

UR013GZ03 Body Only

STANDARD EQUIPMENT: Fast charger, battery cartridges, Nylon cutting head, shoulder belt, box wrench, hex wrench



## 40V Max XGT Brushless Linetrimmer

UR014G

Max output	1,500W	<b>ANTI-RESTART FUNCTION</b>
No Load Speed	4,000 – 5,700rpm	
Spindle Size	M10 x 1.25L	
Cutting Diameter	450mm	
Net Weight	5.5 – 6.7Kg	



### Model Versions

UR014GT201 2x 5.0Ah  
UR014GZ Body Only

STANDARD EQUIPMENT: Fast charger, battery cartridges, Nylon cutting head, shoulder belt, box wrench, hex wrench

## 40V Max XGT Brushless Brush Cutter

UR006G

Max output	1,000W
Speed Settings	3 speed + ADT mode
No Load Speed (L/M/H)	0 - 4,600 / 0 - 5,500 / 0-7,000 rpm
Spindle Size	M10 x 1.25 L
Cutting Diameter	430mm
Net Weight	5.7 – 6.3kg



### Model Versions

UR006GZ04 Body Only

STANDARD EQUIPMENT: Nylon cutting head, accessory bag, hex wrench, box wrench, shoulder belt.

## 40V Max XGT Brushless Linetrimmer

UR008G

Max output	1,000W
Speed Settings	3 speed + ADT mode
No Load Speed (L/M/H)	0 - 4,000 / 0 - 4,600 / 0-6,000 rpm
Spindle Size	M10 x 1.25 L
Cutting Diameter	430mm
Net Weight	5.0 – 5.7kg



### Model Versions

UR008GD202 2x 2.5Ah  
UR008GZ01 Body Only

STANDARD EQUIPMENT: Fast charger, battery cartridges, Nylon cutting head, accessory bag, hex wrench, shoulder belt.

## 40V Max XGT Brushless Linetrimmer

UR017G

Max output	600W	<b>ANTI-RESTART FUNCTION</b>
Speed settings	3 speed + ADT mode	
No Load Speed	3,500 / 5,300 / 6,500rpm	
Spindle Size	M10 x 1.25 L	
Cutting Diameter	330mm	
Net Weight	4.2 – 4.8Kg	



### Model Versions

UR017GM101 1x 4.0Ah  
UR017GZ Body Only

STANDARD EQUIPMENT: Fast charger, battery cartridge, shoulder belt, box driver, hex wrench

## 40V Max XGT Brushless Brush Cutter

UR016G

Max output	600W	<b>ANTI-RESTART FUNCTION</b>
Speed settings	3 speed + ADT mode	
No Load Speed	3,500 / 5,300 / 6,500 rpm	
Spindle Size	M10 x 1.25 L	
Cutting Diameter	330 mm	
Net Weight	4.7 – 5.3Kg	



### Model Versions

UR016GM101 1x 4.0Ah  
UR016GZ Body Only

STANDARD EQUIPMENT: Fast charger, battery cartridge, shoulder belt, Box wrench, Hex wrench

## ACCESSORIES: CUTTING HEADS



**198893-8**  
Cutter Assembly  
95-M10L



**197296-3**  
Cutter Assembly  
M10X1.25LH



**198383-1**  
Plastic Blade  
Head 255 Set

To see the full range of lines and blades visit [www.makita.com](http://www.makita.com)



## 40V Max XGT Brushless Brush Cutter

UR002G

Max output	550W
Speed Settings	3-speed + ADT mode
No Load Speed (L/M/H)	3,500 / 5,300 / 6,500rpm
Spindle Size	M10 x 1.25 L
Cutting Diameter	350mm
Net Weight	4.6 – 5.3kg



### Model Versions

UR002GD202 2x 2.5Ah

UR002GZ Body Only

STANDARD EQUIPMENT: Fast charger, battery cartridges, Nylon cutting head, accessory bag, hex wrench, box wrench, shoulder belt.

## 40V Max XGT Brushless Linetrimmer

UR003G

Max output	550W
Speed Settings	3-speed + ADT mode
No Load Speed (L/M/H)	3,500 / 5,300 / 6,500rpm
Spindle Size	M10 x 1.25 L
Cutting Diameter	350mm
Net Weight	4.5 – 4.8kg



### Model Versions

UR003GD202 2x 2.5Ah

UR003GZ Body Only

STANDARD EQUIPMENT: Fast charger, battery cartridges, Nylon cutting head, accessory bag, hex wrench, box driver, shoulder belt.

## 40V Max XGT Brushless Blower

UB001G

No Load Speed	0-20,000rpm (Cruise control mode) 0-23,000 rpm (Boost mode)	Max Air Velocity	53 m/sec (Cruise control mode) 64 m/sec (Boost mode)
Max Air Volume	0-13.5 m³/min (Cruise control mode) 16.0 m³/min (Boost mode)	Net Weight	3.1-3.9kg



### Model Versions

UB001GD202 2x 2.5Ah

UB001GZ Body Only

STANDARD EQUIPMENT: Fast charger, battery cartridges, shoulder belt end nozzle, adapter pipe, extension nozzle, flat nozzle.

## 40V Max XGT Brushless Backpack Mist Blower

PM001G

No Load Speed	25,000 rpm
Max speed in high speed mode	
Blowing Force	15.0N
Max Air Volume	14.3 m³/min
Average air speed	53.0 m/s
Max air speed	64.0 m/s
Max spray range (horizontal)	14 m
Tank Capacity	15L
Net Weight	13.2 – 15.7kg



### Model Versions

PM001GL202 2x 8.0Ah

PM001GZ01 Body Only

STANDARD EQUIPMENT: Fast charger, battery cartridges, Nozzle 0.5, wrench, diffusion cover.

## 40V Max XGT Brushless Hedge Trimmers

UH004G  
UH005G

Blade Length	UH004G: 60cm UH005G: 75cm	<b>SHARP EDGE CURVED BLADE: IDEAL FOR TRIMMING</b>
No Load Speed (Lo/Med/Hi)	2,000 / 3,600 / 5,000 spm	
Blade Type	Double Sided	
Max Branch Diameter	23.5mm	
Net Weight	UH004G: 4.3 – 4.9kg UH005G: 4.5 – 5.1kg	



### Model Versions

UH004GD201 2x 2.5Ah

UH004GZ Body Only

UH005GD201 2x 2.5Ah

UH005GZ Body Only

STANDARD EQUIPMENT: Fast charger, battery cartridges, blade cover.

## 40V Max XGT Brushless Hedge Trimmers

UH006G  
UH007G

Blade Length	UH006G: 60cm UH007G: 75cm	<b>SHARP EDGE BLADE: IDEAL FOR ROUGH CUT</b>
No Load Speed (Lo/Med/Hi)	2,000 / 3,000 / 4,000 spm	
Blade Type	Double Sided	
Max Branch Diameter	25mm	
Net Weight	UH006G: 4.4 – 5.0kg UH007G: 4.6 – 5.2kg	



### Model Versions

UH006GD201 2x 2.5Ah

UH006GZ Body Only

UH007GD201 2x 2.5Ah

UH007GZ Body Only

STANDARD EQUIPMENT: Fast charger, battery cartridges, blade cover.

## 40V Max XGT Brushless Hedge Trimmers

UH013G  
UH014G

Blade Length	UH013G: 60cm UH014G: 75cm
No Load Speed (Lo/Med/Hi)	2,000 / 3,600 / 5,000 spm
Blade Type	Single sided
Max Branch Diameter	23.5mm
Net Weight	UH013G: 3.9-4.5 kg UH014G: 4.0-4.7 kg



### Model Versions

**UH013GD202** 2x 2.5Ah  
**UH013GZ** Body Only  
**UH014GD202** 2x 2.5Ah  
**UH014GZ** Body Only

STANDARD EQUIPMENT: Fast charger, battery cartridges, blade cover, chip receiver.

## 40V Max XGT Brushless Lawnmower

LM001G

Max output	1,900 W	<b>RECOMMENDED FOR LAWNS OF UP TO 2,100M<sup>2</sup></b>
No Load Speed:		
Standard Mode	3,200 rpm	
Soft No-Load Mode	2,500 – 3,200 rpm	
Cutting Width	480 mm	
Height Adjustment	20 – 100 mm (10 stages)	
Box Capacity	62 L	
Net Weight	28.0 – 33.0kg	



### Model Versions

**LM001GT204** 2x 5.0Ah  
**LM001GZ** Body Only

STANDARD EQUIPMENT: Fast charger, battery cartridges, rod, mulching plug, discharge chute, wrench.

## 40V Max XGT Brushless Lawnmower

LM002G

Max output	1,900 W	<b>RECOMMENDED FOR LAWNS OF UP TO 2,500M<sup>2</sup></b>
No Load Speed:		
Standard Mode	2,800 rpm	
Soft No-Load Mode	2,300 – 2,800 rpm	
Cutting Width	534 mm	
Height Adjustment	20 – 100 mm (10 stages)	
Box Capacity	70 L	
Net Weight	29.3 – 34.5kg	



### Model Versions

**LM002GT204** 2x 5.0Ah  
**LM002GZ** Body Only

STANDARD EQUIPMENT: Fast charger, battery cartridges, rod, mulching plug, discharge chute, wrench.

## 40V Max XGT Lawnmower

LM003G

Max output	740W	<b>RECOMMENDED FOR LAWNS OF UP TO 780M<sup>2</sup></b>
(with an 8.0 Ah battery)		
No Load Speed	3,800 rpm	
Cutting Width	380mm	
Height Adjustment	20 – 75 (8 stages)	
Box Capacity	40L	
Net Weight	14.9 – 17.3kg	



### Model Versions

**LM003GM103** 1x 4.0Ah  
**LM003GZ** Body Only

STANDARD EQUIPMENT: Fast charger, battery cartridge, mulching plug, box wrench.

## 40V Max XGT Lawnmower

LM004G

Max output	740W	<b>RECOMMENDED FOR LAWNS OF UP TO 830M<sup>2</sup></b>
(with an 8.0 Ah battery)		
No Load Speed	3,800 rpm	
Cutting Width	430mm	
Height Adjustment	20 – 75 (8 stages)	
Box Capacity	50L	
Net Weight	15.6 – 18.2kg	



### Model Versions

**LM004GM103** 1x 4.0Ah  
**LM004GZ** Body Only

STANDARD EQUIPMENT: Fast charger, battery cartridge, mulching plug, box wrench.

## 40V Max XGT Brushless Scarifier

UV001G

Max output	1,700 W	<b>RECOMMENDED FOR LAWNS OF UP TO 510M<sup>2</sup></b>
No Load Speed	3,200 rpm	
Working width	380 mm	
Working depth	+5 to -12 mm	
Handle Height Adjustment	2 stages	
Collection container capacity	50L	
Net Weight	18.7 – 23.8kg	



### Model Versions

**UV001GM201** 2x 4.0Ah  
**UV001GZ** Body Only

STANDARD EQUIPMENT: Fast charger, battery cartridges, Thatching blade, box wrench.

## 18V x2 (36V) LXT Brushless Chainsaw

DUC305/  
355/405

Max Output	1,100W	Chain Speed	0-20 m/s
Bar Length	305: 30cm	Oil Tank Capacity	200ml
	355: 35cm / 405: 40cm	Net Weight	305: 4.6-5.3kg
Chain Pitch & Gauge	3/8" / 0.043"		355: 4.7-5.4kg / 405: 4.8-5.5kg



**AUTOMATIC CHAIN OILING**

### Model Versions

- DUC305PG2 2x 6.0Ah
- DUC305PT2 2x 5.0Ah
- DUC305Z Body Only
- DUC355PG2 2x 6.0Ah
- DUC355PT2 2x 5.0Ah
- DUC355Z Body Only
- DUC405PG2 2x 6.0Ah
- DUC405PT2 2x 5.0Ah
- DUC405Z Body Only



**LXT** **LXT 36V** **BL MOTOR**

STANDARD EQUIPMENT: Fast charger, battery cartridges, saw chain, guide bar, chain cover, oil supply, box wrench.

## 18V x2 (36V) LXT Brushless Chainsaw

DUC353

Max Output	1,100W	<b>AUTOMATIC CHAIN OILING</b>
Bar Length	35cm	<b>TOOL-LESS CHAIN CHANGE</b>
Chain Pitch	3/8"	
Chain Gauge	0.043"	
Chain Speed	0-20 m/s	
Oil Tank Capacity	200ml	
Net Weight	4.6-5.5kg	



### Model Versions

- DUC353PG2 2x 6.0Ah
- DUC353PT2 2x 5.0Ah
- DUC353Z Body Only



**LXT** **LXT 36V** **BL MOTOR**

STANDARD EQUIPMENT: Fast charger, battery cartridges, Saw Chain, Guide Bar, Guide Bar Cover, Oil supply.

## 18V LXT Brushless Chainsaw

DUC307  
DUC357

Max Output	610 W	Chain Speed	7.7 m/s
Bar Length	DUC305: 300mm	Oil Tank Capacity	150 ml
	DUC357: 350mm	Net Weight	4.2 - 4.4Kg
Chain Type	DUC305: 90PX		
	DUC357: 90/91 PX		
Chain Pitch	3/8"	<b>TOOL-LESS CHAIN CHANGE</b>	
Chain Gauge	DUC307: 1.1 mm		
	DUC357: 1.1 - 1.3mm		



### Model Versions

- DUC357RT 1x 5.0Ah
- DUC357Z Body Only
- DUC307RTX2 1x 5.0Ah
- DUC307ZX2 Body Only

STANDARD EQUIPMENT: Fast charger, battery cartridge, Oil supply, Guide bar, Chain cover, Saw chain.



**LXT** **BL MOTOR**

## 18V LXT Brushless Top Handle Chainsaw

DUC254

Max Output	570W
Bar Length	25cm
Chain Pitch	3/8"
Chain Gauge	0.043"
Chain Speed	0-24m/s
Oil Tank Capacity	140ml
Net Weight	2.8-3.3kg

**AUTOMATIC CHAIN OILING**



### Model Versions

- DUC254RT 1x 5.0Ah
- DUC254Z Body Only

STANDARD EQUIPMENT: Fast charger, battery cartridges, Chain cover, guide bar, saw chain, wrench, oil set, accessory bag.



**LXT** **BL MOTOR**

**TO BE USED BY TRAINED TREE SURGEONS ONLY**

## 18V x2 (36V) LXT Brushless Top Handle Chainsaw

DUC256  
DUC306

Bar Length	DUC256/256C 25cm	Chain Gauge	DUC256/306: 0.043"
	DUC256C: 30cm		DUC256C: 0.050"
Bar Type	DUC256/306: Sprocket	Chain Speed	0 - 20 m/s
	DUC256C: Carving	Net Weight	DUC256/306: 4.6-5.1kg
Chain Pitch	DUC256/306: 3/8"		DUC256CZ: 4.6-4.8kg
	DUC256C: 1/4"		



### Model Versions

- DUC256PG2 2x 6.0Ah
- DUC256PT2 2x 5.0Ah
- DUC256Z Body Only
- DUC256CZ Body Only
- DUC306PG2 2x 6.0Ah
- DUC306PT2 2x 5.0Ah
- DUC306Z Body Only

STANDARD EQUIPMENT: Fast charger, battery cartridges, Saw Chain, Guide Bar, Guide Bar Cover, Spike Bumper. DUC256C: 25mm Carving bar and chain



**LXT** **LXT 36V** **BL MOTOR**

**TO BE USED BY TRAINED ARBORISTS ONLY**

## 18V x2 (36V) LXT Brushless Telescopic Pole Saw

DUA301

Max output Power	1,000 W
No Load chain speed	0-20 m/s
Bar length	300mm
Chain pitch	3/8"
Chain gauge	0.050"
Saw chain type	91PX-46
Oil tank capacity	160ml
Net weight	7.8 - 8.5kg



### Model Versions

- DUA301PG2 2x 6.0Ah
- DUA301PT2 2x 5.0Ah
- DUA301Z Body Only

STANDARD EQUIPMENT: Fast charger, battery cartridges, saw chain, wrench, hex wrench, band assembly, guide bar, chain protection cover, round file, oil supply, lubricant.



OVERALL LENGTH (EXCLUDING CHAIN BAR) 2.6 - 3.8M METERS

**LXT** **LXT 36V** **BL MOTOR** **AFT**

36V LXT Connect X Brushless Brush Cutter

UR101C

Max Output	1,000W
Speed Settings	3-speed + ADT mode
No Load Speed	0-4,600/ 0-5,500/ 0-7,000 rpm
Spindle Size	M10 x 1.25 L
Cutting Diameter	430mm
Net Weight	5.2kg

**POWERED BY BACK PACK POWER SUPPLY ONLY (SEE PAGE 7)**



**CONNECT X**  
**ADT AFT**  
**LXT BL MOTOR**



Model Versions

**UR101CX1** Includes PDC1200A02

**UR101CZ** Body Only

STANDARD EQUIPMENT: Harness, Metal 2-tooth blade, Plastic blade, Nylon cutting head, Blade guard, Box wrench, Hex wrench, Accessory bag

36V LXT Connect X Brushless Linetrimmer

UR201C

Max Output	1,000W
Speed Settings	3-speed + ADT mode
No Load Speed	0-4,600/ 0-5,500/ 0-7,000 rpm
Spindle Size	M10 x 1.25 L
Cutting Diameter	430mm
Net Weight	4.7kg

**POWERED BY BACK PACK POWER SUPPLY ONLY (SEE PAGE 7)**



**CONNECT X**  
**ADT AFT**  
**LXT BL MOTOR**



Model Versions

**UR201CX1** Includes PDC1200A02

**UR201CZ** Body Only

STANDARD EQUIPMENT: Harness, Metal 2-tooth blade, Plastic blade, Nylon cutting head, Blade guard, Box wrench, Hex wrench, Accessory bag

18V x2 (36V) LXT Brushless Brush Cutter

DUR369A

Max Output	1,000W
Speed Settings	3-speed + ADT mode
No Load Speed (L/M/H)	0-4,600/ 0-5,500/ 0-7,000 rpm
Spindle Size	M10 x 1.25 L
Cutting Diameter	430mm
Net Weight	5.9 - 6.5kg

**ADT**  
**BL MOTOR**  
**AFT**  
**LXT LXT 36V**  
18V + 18V



Model Versions

**DUR369APG2** 2x 6.0Ah

**DUR369APT2** 2x 5.0Ah

**DUR369AZ** Body Only

STANDARD EQUIPMENT: Fast charger, battery cartridges, harness, Metal 2-tooth blade, Plastic blade, Nylon cutting head, Blade guard, Box wrench, Hex wrench, Accessory bag



18V x2 (36V) LXT Brushless Linetrimmer

DUR369L

Max Output	1,000W
Speed Settings	3-speed + ADT mode
No Load Speed (L/M/H)	0-4,600/ 0-5,500/ 0-7,000 rpm
Spindle Size	M10 x 1.25 L
Cutting Diameter	430mm
Net Weight	5.7 - 6.3kg

**ADT**  
**BL MOTOR**  
**AFT**  
**LXT LXT 36V**  
18V + 18V



Model Versions

**DUR369LPG2** 2x 6.0Ah

**DUR369LPT2** 2x 5.0Ah

**DUR369LZ** Body Only

STANDARD EQUIPMENT: Fast charger, battery cartridges, Harness, Metal 2-tooth blade, Plastic blade, Nylon cutting head, Blade guard, Box wrench, Hex wrench, Accessory bag



18V x2 (36V) LXT Brushless Brush Cutter

DUR368A

Max Output	550W
Speed Settings	3-speed + ADT mode
No Load Speed (L/M/H)	3,500 / 5,300 / 6,500 rpm
Spindle Size	M10 x 1.25 L
Cutting Diameter	350mm (Nylon line head)
Net Weight	4.1-4.7kg

**ADT**  
**BL MOTOR**  
**AFT**  
**LXT LXT 36V**  
18V + 18V



Model Versions

**DUR368APG2** 2x 6.0Ah

**DUR368APT2** 2x 5.0Ah

**DUR368AZ** Body Only

STANDARD EQUIPMENT: Fast charger, battery cartridges, Safety goggles, nylon cutting head, accessory bag, hex wrench, box driver, shoulder belt.



18V x2 (36V) LXT Brushless Linetrimmer

DUR368L

Max Output	550W
Speed Settings	3-speed + ADT mode
No Load Speed (L/M/H)	3,500 / 5,300 / 6,500 rpm
Spindle Size	M10 x 1.25 L
Cutting Diameter	350mm (Nylon line head)
Net Weight	3.9-4.5kg

**ADT**  
**BL MOTOR**  
**AFT**  
**LXT LXT 36V**  
18V + 18V



Model Versions

**DUR368LPT2** 2x 5.0Ah

**DUR368LPG2** 2x 6.0Ah

**DUR368LZ** Body Only

STANDARD EQUIPMENT: Fast charger, battery cartridges, nylon cutting head, accessory bag, hex wrench, box driver, shoulder belt.



18V LXT Brushless Linetrimmer

DUR190L  
DUR191L

Max Output	240W
Speed Settings	3-speed + ADT mode
No Load Speed (L/M/H)	3,500/ 5,100/ 6,000rpm
Cutting Diameter	300mm (Nylon line head)
Spindle Size	M10 x 1.25 L
Net Weight	DUR190L: 2.9-3.2kg DUR191L: 3.2-3.5kg

**DUR191L: 2-PART DESIGN FOR EASY STORAGE AND TRANSPORT**



Model Versions

- DUR190LRT8 1x 5.0Ah
- DUR190LZX3 Body Only
- DUR191LRT8 1x 5.0Ah
- DUR191LZX3 Body Only

STANDARD EQUIPMENT: Fast Charger, battery cartridge, shoulder strap, hex wrench, nylon cutting head, accessory bag.



18V LXT Brushless Brush Cutter

DUR190U  
DUR191U

Max Output	240W
Speed Settings	3-speed + ADT mode
No Load Speed (L/M/H)	3,500/ 5,100/ 6,000rpm
Cutting Diameter	300mm (Nylon line head)
Spindle Size	M10 x 1.25 L
Net Weight	DUR190U: 3.1-3.4kg DUR191U: 3.4-3.7kg

**DUR191U: 2-PART DESIGN FOR EASY STORAGE AND TRANSPORT**



Model Versions

- DUR190URT8 1x 5.0Ah
- DUR190UZ3 Body Only
- DUR191URT8 1x 5.0Ah
- DUR191UZ3 Body Only

STANDARD EQUIPMENT: Fast Charger, battery cartridge, shoulder strap, hex wrench, nylon cutting head, accessory bag.



18V LXT Brushless Linetrimmer

DUR192L

Max Output	460W
Speed Settings	2-Speed
No Load Speed (L/H)	0- 4,500 / 0 - 6,000 rpm
Spindle Size	M10 x 1.25 L
Cutting Diameter	300mm
Net Weight	2.7 - 3.0 kg

**2-PART DESIGN FOR EASY STORAGE AND TRANSPORT**



Model Versions

- DUR192LRT 1x 5.0Ah
- DUR192LZ Body Only

STANDARD EQUIPMENT: Fast charger, battery cartridge, nylon cutting head, hex wrench, shoulder belt.



18V LXT Linetrimmer

DUR194

Max Output	230W
Speed Settings	2-Speed
No Load Speed (L/H)	0- 4,500 / 0 - 6,000 rpm
Spindle Size	M10 x 1.25 L
Cutting Diameter	280mm
Net Weight	2.6 - 2.9 kg



Model Versions

- DUR194RTX2 1x 5.0Ah
- DUR194ZX3 Body Only

STANDARD EQUIPMENT: Fast charger, Battery cartridge, Band Assembly, Hex wrench, Box driver, Trimmer head assembly



18V LXT Brushless Linetrimmer

DUR189

Max Output	240W
Speed Settings	3-Speed + ADT Mode
No Load Speed (L/M/H)	4,000 / 5,000 / 6000rpm
Spindle Size	M8 x 1.25RH
Cutting Diameter	300mm
Net Weight	3.0-3.3kg



Model Versions

- DUR189RT 1x 5.0Ah
- DUR189Z Body Only

STANDARD EQUIPMENT: Fast charger, battery cartridges, Single harness, nylon cutting head, accessory bag, hex wrench.



18V LXT Linetrimmer

DUR193

No Load Speed	7,800 rpm	<b>EDGER FUNCTION</b>
Cutting Diameter	260 mm	
Cord feed system	Bump & Feed	
Nylon cord	1.65 mm	
Shaft adjustment range	190 mm	
Net Weight	2.3 - 2.6 Kg	

Model Versions

- DUR193RT 1x 5.0Ah
- DUR193Z Body Only

STANDARD EQUIPMENT: Fast charger, battery cartridge, Nylon cutting head, Shoulder belt



# LXT CORDLESS

# CORDLESS SPLIT-SHAFT ATTACHMENTS

## 18V x2 (36V) LXT Brushless Split-Shaft DUX60

No Load Speed (Hi) 0 - 9,700 rpm  
 No Load Speed (Med) 0 - 8,200 rpm  
 No Load Speed (Lo) 0 - 5,700 rpm  
 Max Output 600 W  
 Net Weight 4.1-8.7kg

**191F65-0 IS NOT COMPATIBLE WITH DUX60 MACHINES WITH SERIAL NUMBER LOWER THAN 85630 AND ENDING IN Y**



**Model Versions**  
**DUX60PG2** 2x 6.0Ah  
**DUX60PT2** 2x 5.0Ah  
**DUX60Z** Body Only

STANDARD EQUIPMENT: Fast charger, battery cartridge, shoulder strap, hex wrench, safety goggles, accessory bag.



## 18V LXT Brushless Split-Shaft DUX18

No Load Speed (Hi) 0 - 9,700 rpm  
 No Load Speed (Lo) 0 - 6,800 rpm  
 Max Output 470W  
 Net Weight 2.8 - 10.3kg

**198768-1 AND 198779-6 ARE NOT COMPATIBLE WITH THE DUX18**



**Model Versions**  
**DUX18RT** 1x 5.0Ah  
**DUX18Z** Body Only

STANDARD EQUIPMENT: Fast charger, battery cartridge, shoulder strap, hex wrench, accessory bag.



## 18V x2 (36V) LXT Brushless Earth Auger DDG460

No Load Speed (High) 0-1,400 rpm  
 No Load Speed (Low) 0-350 rpm  
 Chuck Capacity 2-13mm  
 Max Drilling Capacity 200mm  
 Capacity (High resistance soil) 150mm  
 Capacity (Low resistance soil) 200mm  
 Max Torque (H/L) 48 / 136Nm  
 Net Weight 7.3-8.2kg

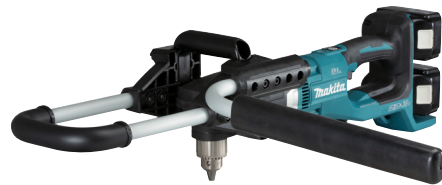

**Model Versions**  
**DDG460T2X7** 2x 5.0Ah  
**DDG460Z7** Body Only

STANDARD EQUIPMENT: Fast charger, battery cartridges, Chuck key, Hex wrench, Adaptor x2.

Brush Cutter	Brush Cutter	Linetrimmer	Linetrimmer	Scissors
198768-1 / EM404MP	191N31-5 / EM408MP	198779-6 / EM406MP	191N49-6 / EM409MP	191M56-3 / EM407MP



Cultivator	Edging Tool	Extension Pole	Pole Saw	Hedge Trimmer
195711-1 / KR400MP	196752-0 / EE400MP	191E24-8 / LE400MP	191T38-7 / EY403MP	196256-2 / EN401MP



Hedge Trimmer	Ground Trimmer	Ground Trimmer	Power Brush	Sweeper
1912T8-8 / EN402MP	1912T0-4 / EN422MP	1913C9-3 / EN424MP	199318-5 / BR400MP	199339-7 / SW400MP



Blower	Blower	Blower	Water Pump
191F65-0 / UB400MP	191P72-3 / UB401MP	1912R8-4 / UB402MP	DEAPF400MP / PF400MP



## 18V LXT Brushless Blower & Vacuum DUB187

Vacuum Mode

Max Air Volume	6.1 m <sup>3</sup> /min
Max sealed suction	3.3 kPa
Dust bag capacity	25L
Net Weight	3.7 – 4.0 Kg

Blower Mode

Max Air Volume	4.2 m <sup>3</sup> /min
Max Air Velocity	64.0 m/sec
No Load Speed	9,000 – 13,500 rpm
Net Weight	3.7 – 4.0 Kg

### BLOWER AND VACUUM MODE



### Model Versions

**DUB187Z** Body Only

STANDARD EQUIPMENT: Collection bag, shoulder harness

## 18V x2 (36V) LXT Brushless Blower DUB363

No Load Speed	0 - 7,850rpm
Max Air Volume	13.4 m <sup>3</sup> /min
Max Air Velocity	65 m/s
Net Weight	4.5 – 6.6kg

### VACUUM ATTACHMENT KIT

The DUB363 can be converted into vacuum using the kit which includes a 2 piece nozzle, collection bag and shoulder strap.



### Model Versions

**DUB363PT2V** 2x 5.0Ah

**DUB363PG2V** 2x 6.0Ah

**DUB363ZV** Body Only

STANDARD EQUIPMENT: Fast charger, battery cartridges, vacuum kit, flat nozzle, end nozzle, pipe, shoulder belt, hex wrench.

## 18V x2 (36V) LXT Brushless Blower DUB362

No load speed	11,400 – 21,500 rpm
Max air volume	6.9 – 13.4 m <sup>3</sup> /min
Max air velocity	27-54 m/s
Net weight	3.5-4.2kg

**6 AIR VOLUME/VELOCITY SETTINGS**  
**LOCK ON FUNCTION**  
**BATTERY FUEL GAUGE**



### Model Versions

**DUB362PG2** 2x 6.0Ah

**DUB362PT2** 2x 5.0Ah

**DUB362Z** Body Only

STANDARD EQUIPMENT: Fast charger, battery cartridges, Long nozzle, shoulder strap.

## 18V LXT Brushless Blower DUB184

No Load Speed	0-18,000rpm
Max. Air Volume	13.0 m <sup>3</sup> /min
Max. Air Velocity	52.1 m/s
Run time (6.0Ah)	12mins
Net Weight	2.5-3.0kg



### Model Versions

**DUB184RT** 1x 5.0Ah

**DUB184Z** Body Only

STANDARD EQUIPMENT: Fast charger, battery cartridges, Shoulder belt, nozzle, hex wrench.



## 36V LXT Connect X Brushless Blower UB001C

No Load Speed	0 – 21,000rpm
Cruise control mode	0 – 21,000rpm
Boost mode	24,000rpm
Max Air Volume	0 – 15 m <sup>3</sup> /min
Cruise control mode	0 – 15 m <sup>3</sup> /min
Boost mode	17.6 m <sup>3</sup> /min
Max Air Velocity	0 – 60 m/sec
Cruise control mode	0 – 60 m/sec
Boost mode	70 m/sec
Net weight	2.6 – 2.9kg

**POWERED BY BACK  
PACK POWER SUPPLY  
ONLY (SEE PAGE 7)**



### Model Versions

**UB001CX2** Includes PDC1200A02

**UB001CZ** Body Only

STANDARD EQUIPMENT: Shoulder strap, Nozzle assembly.



## 36V LXT Connect X Brushless Blower UB003C

No Load Speed	4,000 – 10,600rpm
	4,000 – 17,700rpm
	4,000 – 22,100rpm
Max Air Volume	2.9 – 8.2 m <sup>3</sup> /min
	2.9 – 13.9 m <sup>3</sup> /min
	2.9 – 17.6 m <sup>3</sup> /min
Max Air Velocity	86.0 m/sec
Net Weight	2.8 – 3.1Kg

**POWERED BY BACK  
PACK POWER SUPPLY  
ONLY (SEE PAGE 7)**



### Model Versions

**UB003CZ** Body Only

STANDARD EQUIPMENT: Shoulder strap, Nozzle assembly.



36V LXT Connect X Brushless Backpack Blower

UB002C

No Load Speed	0 – 22,000 rpm
Blowing Force	0 – 22.0N
Max Air Volume:	
With End nozzle 82	0 – 19.0 m <sup>3</sup> /min
With Flat nozzle	0 – 17.9 m <sup>3</sup> /min
Max Air Velocity:	
With End nozzle 82	0 – 71.7 m/sec
With Flat nozzle	0 – 76.0 m/sec
Net Weight	15.9 – 16.1kg

**POWERED BY BACK PACK POWER SUPPLY ONLY (SEE PAGE 7)**

**ANTI-RESTART FUNCTION**



**LXT BL MOTOR CONNECT X**



Model Versions

**UB002CX3** Includes PDC1200A02

**UB002CZ** Body Only

STANDARD EQUIPMENT: Adaptor pipe.

18V LXT Blower

DUB186

Max Air Volume	3.2m <sup>3</sup> /min
Max Air Velocity	68 m/sec
No Load Speed	0 – 18,000rpm
Net Weight	1.6-2.1kg



**LXT**



Model Versions

**DUB186RT** 1x 5.0Ah

**DUB186Z** Body Only

STANDARD EQUIPMENT: Fast charger, battery cartridge, garden nozzle.

18V LXT Brushless Hedge Trimmers

DUH502/  
601/751

Blade length	DUH502Z: 50cm	Blade type	Double Sided
	DUH601Z: 60cm		DUH502Z: 21.5mm
	DUH751Z: 75cm		DUH601Z: 23.5mm
No load speed	Lo: 0-2,000spm	Net weight	3.8-4.5kg
	Mid: 0-3,600spm		
	Hi: 0-4,400spm		

**DUH601Z / DUH751Z:**  
**LOW FRICTION BLADES FOR MORE EFFICIENT CUTTING**



**LXT BL MOTOR**



Model Versions

**DUH502RT** 1x 5.0Ah

**DUH502Z** Body Only

**DUH601RT** 1x 5.0Ah

**DUH601Z** Body Only

**DUH751RT** 1x 5.0Ah

**DUH751Z** Body Only

STANDARD EQUIPMENT: Fast charger, battery cartridges, Blade cover.

18V LXT Brushless Hedge Trimmers

DUH604S  
DUH754S

Blade Length	DUH604S: 60cm	
	DUH754S: 75cm	
No Load Speed	2,000/ 3,600/ 4,400 spm	
	Blade Type	Single sided
	Max Branch Diameter	23.5mm
Net Weight	3.4 – 3.9kg	



**LXT BL MOTOR**

Model Versions

**DUH604SRT** 1x 5.0Ah

**DUH604SZ** Body Only

**DUH754SRT** 1x 5.0Ah

**DUH754SZ** Body Only

STANDARD EQUIPMENT: Fast charger, battery cartridges, Blade Cover, Chip Receiver



18V LXT Brushless Hedge Trimmers

DUH506  
DUH606

Max output	320W	<b>ANTI-RESTART</b>
Blade length	DUH506: 500mm	
		DUH606: 600mm
Strokes per minute	4,000spm	
Max branch diameter	20mm	
Net Weight	DUH506: 2.5 – 2.9Kg	
	DUH606: 2.7 – 3.0 Kg	



**LXT BL MOTOR**

Model Versions

**DUH506RT** 1x 5.0Ah

**DUH506Z** Body Only

**DUH606RT** 1x 5.0Ah

**DUH606Z** Body Only

STANDARD EQUIPMENT: Fast charger, battery cartridge, blade cover.



18V LXT Hedge Trimmers

DUH507  
DUH607

Max output	250W
Blade length	DUH507: 500mm
	DUH607: 600mm
Strokes per minute	2,700spm
Max branch diameter	15mm
Net Weight	DUH507: 2.7 – 3.0Kg
	DUH607: 2.8 – 3.1 Kg



**LXT**

Model Versions

**DUH507RT** 1x 5.0Ah

**DUH507Z** Body Only

**DUH607RT** 1x 5.0Ah

**DUH607Z** Body Only

STANDARD EQUIPMENT: Fast charger, battery cartridge, blade cover.





18V LXT Hedge Trimmer

DUH523

No load speed	1,350spm
Blade length	520mm
Max. branch Ø	15mm
Net weight	3.0-3.4kg



Model Versions

DUH523Z Body Only

STANDARD EQUIPMENT: Blade cover, battery cover.

18V LXT Brushless Pole Hedge Trimmer

DUN500W

Blade Length	500mm	<b>2.1 METERS LONG</b>
Strokes per Minute	2,000/ 3,600/ 4,400 spm	
Max Branch Diameter	23.5mm	<b>HEAD ANGLES FROM 45°-70° 180° FOLDABLE FOR STORAGE</b>
Overall Length	2,115 mm	
Net Weight	3.9 - 4.3kg	



Model Versions

DUN500WRTE 2x 5.0Ah

DUN500WZ Body Only

STANDARD EQUIPMENT: Fast charger, battery cartridges, Blade Cover, Shoulder Harness

18V LXT Pole Hedge Trimmer

DUN461W

Blade Length	460mm	<b>TELESCOPIC PIPE 1.9 - 2.5 METERS LONG</b>
Strokes per Minute	3,600spm	
Max Branch Diameter	10mm	<b>HEAD ANGLES FROM 60°-75°</b>
Overall Length	1,889-2,511mm	
Net Weight	3.0-3.3kg	

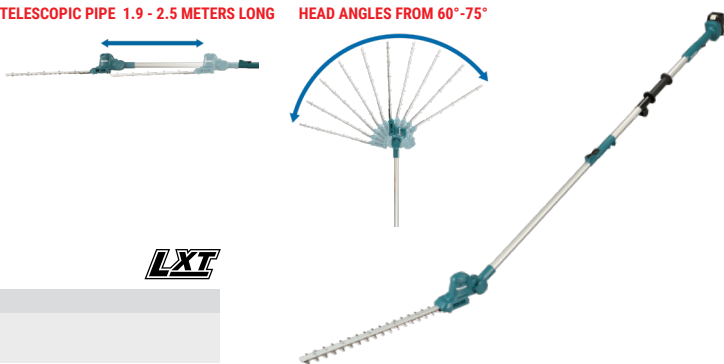

Model Versions

DUN461WRT 1x 5.0Ah

DUN461WZ Body Only

STANDARD EQUIPMENT: Fast charger, battery cartridge, blade cover.

18V LXT Brushless Pole Hedge Trimmer

DUN600L

Blade Length	600mm	<b>2.05 METERS LONG</b>
Strokes per Minute	2,000/ 3,600/ 4,400 spm	
Max Branch Diameter	23.5mm	
Overall Length	2,050 mm	
Net Weight	3.7 - 4.1kg	



Model Versions

DUN600LRTE 2x 5.0Ah

DUN600LZ Body Only

STANDARD EQUIPMENT: Fast charger, battery cartridges, Blade Cover, Hex Wrench

12V Max CXT Pole Hedge Trimmer

UN460WD

Blade Length	460mm	<b>TELESCOPIC PIPE 1.9 - 2.5 METERS LONG</b>
Strokes per Minute	3,600spm	
Max Branch Diameter	10mm	<b>HEAD ANGLES FROM 60°-75°</b>
Overall Length	1,88-2,511mm	
Net Weight	2.8-3.0kg	

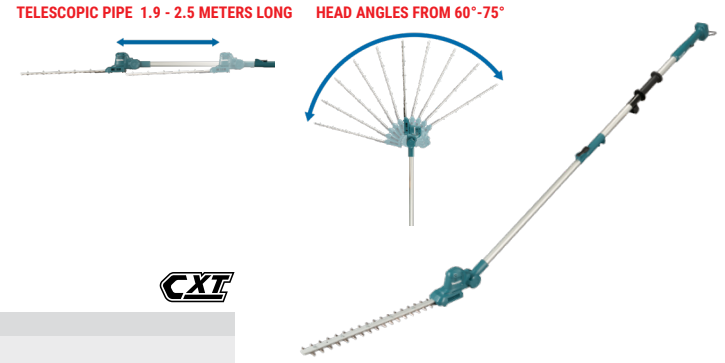

Model Versions

UN460WDZ Body Only

STANDARD EQUIPMENT: Blade cover.

18V LXT Brushless Pruning Saw

DUC150

Max output power	320W
Chain speed	8.0 m/s
Bar length	150 mm
Chain pitch	0.325"
Chain Gauge	1.1 mm
Saw chain type	80 TXL
Chain number of links	32
Oil tank capacity	55 ML
Net Weight	1.7 - 2.0kg

**TOOL-LESS CHAIN CHANGE**



Model Versions

DUC150RT 1x 5.0Ah

DUC150Z Body Only

STANDARD EQUIPMENT: Fast charger, battery cartridge, guide bar, guide bar case, file guide and file, oil set, saw chain.



# LXT / CXT CORDLESS

## 12V Max CXT Brushless Pruning Saw

UC100D

Max output power	210W
Chain speed	8.0 m/s
Bar length	100 mm
Chain pitch	0.325"
Chain Gauge	1.1 mm
Saw chain type	80 TXL
Chain number of links	26
Oil tank capacity	55 ML
Net Weight	1.5 – 1.6 kg

**TOOL-LESS CHAIN CHANGE**



### Model Versions

**UC100DWA** 1x 2.0Ah  
**UC100DZ** Body Only

STANDARD EQUIPMENT: Standard charger, battery cartridge, guide bar, guide bar case, file guide and file, oil set, saw chain.



## 18V x2 (36V) LXT Pruning Shears

DUP362

Max Cutting Capacity	33mm
Max Blade Opening	54mm
Cutting Torque	250Nm
Net Weight	3.3-3.9kg

### Model Versions

**DUP362Z** Body Only

STANDARD EQUIPMENT: Oil supply, wrench set, diamond file, cord holder, holster, harness, arm band, tool bag, shear blade.



## 18V x2 (36V) LXT Pruning Shears

DUP361

Max Cutting Capacity	33mm
Max Blade Opening	54mm
Cutting Torque	185Nm
Net Weight	3.3-3.8kg

### Model Versions

**DUP361ZN** Body Only

STANDARD EQUIPMENT: Oil supply, wrench set, diamond file, cord holder, holster, harness, arm band, tool bag, shear blade.



# LXT / CXT CORDLESS

## 18V LXT Brushless Pruning Shears

DUP180

Max Cutting Capacity	30mm
Max Blade Opening speed	0.3 secs
Net Weight	0.68kg



### Model Versions

**DUP180RT** 1x 5.0Ah  
**DUP180Z** Body Only

STANDARD EQUIPMENT: Fast charger, battery cartridge, holster, dressing stone set, oil supply, battery adapter, box wrench, hex wrench, carry case.



## 12V Max CXT Brushless Pruning Shears

UP100D

Max Cutting Capacity	25 mm
Max Blade Opening speed	0.4 secs
Net Weight	1.1Kg

Body only machines do not come with a carry case.



### Model Versions

**UP100DSMJ** 1x 4.0Ah  
**UP100DZ** Body Only

STANDARD EQUIPMENT: Fast charger, battery cartridge, holster, dressing stone set, oil supply, box wrench, hex wrench, socket screw key, carry case.



## 18V LXT Backpack Garden Sprayer

DUS158Z

Max Pressure	0.5 MPa
Tank Capacity	15L
Hose Length	1.7 m
Spray Wand Length	0.6 m
Nozzle mounting thread	G 1/4
Net Weight	5.9 – 6.2 Kg
Max Net Weight filled	21.2 Kg

### Model Versions

**DUS158Z** Body Only

STANDARD EQUIPMENT: Spray pipe holder, Shoulder harness, Y-shaped double nozzle, Wide angle herbicide nozzle, Measuring cup.



## 18V LXT Garden Sprayer

DUS054

Max pressure	0.3 MPa
Tank capacity	5L
Hose Length	1.7 m
Spray Wand length	0.5 – 0.7 m
Nozzle mounting thread	G ¼
Net weight	3.2 – 3.5kg

### Model Versions

**DUS054Z** Body Only

STANDARD EQUIPMENT: H-Shaped double head nozzle, Spray wand, Spray wand holder, Shoulder belt.



## 12V Max CXT Garden Sprayer

US053D

Max pressure	0.3 MPa
Tank capacity	5L
Hose Length	1.7 m
Spray Wand length	0.5 – 0.7 m
Nozzle mounting thread	G ¼
Net weight	2.9 – 3.0kg

### Model Versions

**US053DZ** Body Only

STANDARD EQUIPMENT: H-Shaped double head nozzle, Spray wand, Spray wand holder, Shoulder belt.

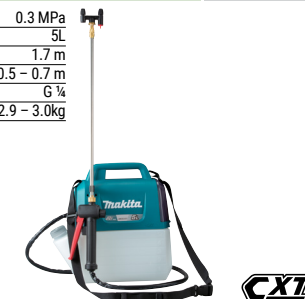

## 18V x2 (36V) LXT Brushless Wheelbarrow with Electric Lift

DCU601

Max Loading Capacity	300kg on flat ground
Max Climbing Angle	180kg on a 12° slope
Forward Speed (3 speeds)	1.5 / 3.5 / 5.0 Km/h
Reverse Speed	1.0 Km/h
Net Weight	144 – 145kg



### Model Versions

DCU601Z Body Only

STANDARD EQUIPMENT: Electric lift, clamp

## 18V x2 (36V) LXT Brushless Wheelbarrow with Dump Bucket

DCU602

Max Loading Capacity	300kg on flat ground
Max Climbing Angle	180kg on a 12° slope
Forward Speed (3 speeds)	1.5 / 3.5 / 5.0 Km/h
Reverse Speed	1.0 Km/h
Net Weight	145 – 147kg



### Model Versions

DCU602Z Body Only

STANDARD EQUIPMENT: Dump Bucket, clamp

## 18V x2 (36V) LXT Brushless Wheelbarrow with Pipe Frame

DCU604

Max Loading Capacity	300kg on flat ground
Max Climbing Angle	180kg on a 12° slope
Forward Speed (3 speeds)	1.5 / 3.5 / 5.0 Km/h
Reverse Speed	1.0 Km/h
Net Weight	119 – 120kg



### Model Versions

DCU604Z Body Only

STANDARD EQUIPMENT: Clamp

## 18V LXT Brushless Wheelbarrow

DCU180

Max Loading Capacity	130 kg
Max Climbing Angle	12°
Forward Speed (Hi)	3.5km/h
Forward Speed (Lo)	1.5km/h
Reverse Speed	1.0km/h
Net weight (Machine only)	32.5kg
Net weight (Pipe frame)	44.5-44.8kg
Net weight (Bucket frame)	39.3-39.6kg

Optional Accessories:  
Pipe Frame



Bucket Frame



### Model Versions

DCU180PTX3 2x 5.0Ah + 199009-8 Pipe Frame

DCU180PTX4 2x 5.0Ah + 199008-0 Bucket Frame

DCU180PT2 2x 5.0Ah

DCU180Z Body Only

STANDARD EQUIPMENT: Wrench x2, support legs, lock key, fast charger, battery cartridges.

DCU180 Pipe Frame	DCU180 Bucket	DCU604/602/601 Pipe Frame	DCU604/602/601 Flat Bucket
199009-8	199008-0	191B67-2	1911B3-6



DCU604/602/601 Dump Bucket	DCU604/602/601 Dump Attachment
191B69-8	191B63-0



## 18V LXT Grass Shears

DUM111

Cycles per Minute	1,250 cpm
Strokes per Minute	2,500 spm
Cutting Width:	
Grass Shear blade	110mm
Hedge Trimmer	200mm
Cutting Heights	15, 20, 25mm
Net Weight	1.4 – 1.8kg

**COMES WITH HEDGE TRIMMER ATTACHMENT**



**LXT**



### Model Versions

**DUM111RTX** 1x 5.0Ah

**DUM111ZX** Body Only

STANDARD EQUIPMENT: Fast charger, battery cartridges, blade cover.

## 18V LXT Grass Shears

DUM604

Cycles per minute	1,250cpm
Strokes per minute	2,500spm
Cutting Width	160mm
Cutting Heights	15, 20, 25mm
Net Weight	1.4-1.8kg

**COMES WITH HEDGE TRIMMER ATTACHMENT**



**LXT**



### Model Versions

**DUM604RTX** 1x 5.0Ah

**DUM604ZX** Body Only

STANDARD EQUIPMENT: Fast charger, battery cartridges, Grass receiver, blade cover

## 12V Max CXT Grass Shears

UM600D

Cycles per minute	1,250 cpm
Strokes per minute	2,500 spm
Cutting Width	160mm
Cutting Heights	15, 20, 25mm
Net Weight	1.3-1.5kg

**COMES WITH HEDGE TRIMMER ATTACHMENT**



**CXT**



### Model Versions

**UM600DZX** Body Only

STANDARD EQUIPMENT: Grass receiver, blade cover, hedge trimmer shear blade, chip receiver.

## 18V (Integrated Battery) Robotic Lawnmower

RM350D

No Load speed of blade	2,300 rpm
No Load speed of wheels	41 rpm
Max climbing angle	26 degrees
Max mowing area	3,500 m <sup>2</sup>
Cutting width	240 mm
Cutting height	20 – 60 mm
Net Weight	13.7Kg

**MAX. WORK AREA 3,500m<sup>2</sup>**

**INTERGRATED BATTERY 18V 5.0AH LI-ION**



### Model Versions

**RM350D** 5.0Ah Intergrated Battery

STANDARD EQUIPMENT: Charging station, boundry wire, guide wire.

## 18V LXT Lawnmower

DLM330

No Load Speed	4,300 rpm
Max output	450 W
Cutting Width	330mm
Height Adjustment	20 -75mm
Net Weight	11.6 – 12.5kg

**RECOMMENDED FOR LAWNS OF UP TO 270m<sup>2</sup>**



**LXT**

### Model Versions

**DLM330RT** 1x 5.0Ah

**DLM330Z** Body Only

STANDARD EQUIPMENT: Fast Charger, battery cartridges, blade, wrench, mulching plug

## 18V x2 (36V) LXT Lawnmower

DLM382

No Load Speed	0 – 3,700rpm
Blade Type	Rotary type 2 tooth
Cutting Width	380mm
Height Adjustment	20-75mm
Collection box	40 litres
Net Weight	16.2-16.9kg

**RECOMMENDED FOR LAWNS OF UP TO 560m<sup>2</sup>**



**LXT LXT 36V**  
18V + 18V

### Model Versions

**DLM382PG2** 2x 6.0Ah

**DLM382CT2** 2x 5.0Ah

**DLM382Z** Body Only

STANDARD EQUIPMENT: Fast Charger, battery cartridges, blade, socket wrench. DLM382CT2 with standard charger.

18V x2 (36V) LXT Lawnmower

DLM432

No Load Speed	3,600rpm
Blade Type	Rotary type 2 tooth
Cutting Width	430mm
Height Adjustment	20 - 75mm
Collection Box	50 litres
Net Weight	16.8 - 17.5kg

**RECOMMENDED FOR LAWNS OF UP TO 575m<sup>2</sup>**



Model Versions

- DLM432PG2 2x 6.0Ah
- DLM432Z Body Only

STANDARD EQUIPMENT: Fast charger, battery cartridges, blade, socket wrench.

18V x2 (36V) LXT Lawnmower

DLM480

No Load Speed	3,100 rpm
Max output	860W
Blade Type	2-tooth blade
Cutting Width	480mm
Height Adjustment	20 - 100mm (10 stages)
Collection Box Capacity	62L
Net Weight	24.5 - 26.8 Kg

**RECOMMENDED FOR LAWNS OF UP TO 800m<sup>2</sup>**



Model Versions

- DLM480CT2 2x 5.0Ah
- DLM480Z Body Only

STANDARD EQUIPMENT: Standard charger, battery cartridges, Rod, Mulching plug, wrench

18V x2 (36V) LXT Lawnmower

DLM481

No Load Speed	3,100 rpm
Max output	860W
Blade Type	2-tooth blade
Cutting Width	480mm
Height Adjustment	20 - 100mm (10 stages)
Collection Box Capacity	62L
Net Weight	27.1 - 29.3 Kg

**RECOMMENDED FOR LAWNS OF UP TO 650m<sup>2</sup>**



Model Versions

- DLM481CT2 2x 5.0Ah
- DLM481Z Body Only

STANDARD EQUIPMENT: Standard charger, battery cartridges, Rod, Mulching plug, wrench

18V x2 (36V) LXT Lawnmower

DLM538

No Load Speed	3,000 rpm
Max output	860W
Blade Type	2-tooth blade
Cutting Width	534mm
Height Adjustment	20 - 100mm (10 stages)
Collection Box	70L
Net Weight	25.5 - 28.0kg

**RECOMMENDED FOR LAWNS OF UP TO 800m<sup>2</sup>**



Model Versions

- DLM538CT2 2x 5.0Ah
- DLM538Z Body Only

STANDARD EQUIPMENT: Battery cartridges, Standard charger, blade, mulching plug, wrench, rod

18V x2 (36V) LXT Lawnmower

DLM539

No Load Speed	3,000 rpm
Max output	860W
Blade Type	2-tooth blade
Cutting Width	534mm
Height Adjustment	20 - 100mm (10 stages)
Collection Box Capacity	70L
Net Weight	27.9 - 30.4 Kg

**RECOMMENDED FOR LAWNS OF UP TO 700m<sup>2</sup>**



Model Versions

- DLM539CT2 2x 5.0Ah
- DLM539Z Body Only

STANDARD EQUIPMENT: Standard charger, battery cartridges, Rod, Mulching plug, wrench

18V x2 (36V) LXT Brushless Lawnmower

DLM460

Max Output	1,450W
No Load Speed	2,500-3,300rpm
Cutting Width	460mm
Blade Type	Rotary type 2 tooth
Height Adjustment	10 settings (20-75mm)
Collection Box	60 litres
Net Weight	25.3-27.6kg

**RECOMMENDED FOR LAWNS OF UP TO 800m<sup>2</sup>**

**STEEL DECK**



Model Versions

- DLM460PG2 2x 6.0Ah
- DLM460PT4 4 x 5.0Ah
- DLM460Z Body Only

STANDARD EQUIPMENT: Battery cartridges, fast charger, socket wrench.

18V x2 (36V) LXT Brushless Lawnmower

DLM462

No Load Speed	2,500 / 3,300 rpm
Cutting Width	460mm
Height Adjustment	20 - 100mm (10-step)
Collection box	60L
Net Weight	35.3 - 39.0kg

**RECOMMENDED FOR LAWNS OF UP TO 1,900m<sup>2</sup>**

**STEEL DECK**

**4 Batteries for extended run time**  
The mower will use 2 batteries at a time. When the first set goes flat turn the switch and keep mowing.



**Model Versions**

- DLM462PT4 4x 5.0Ah
- DLM462PG2 2x 6.0Ah
- DLM462Z Body Only

STANDARD EQUIPMENT: Fast charger, battery cartridges, Blade, Mulch plug, Socket Wrench, Rod

18V x2 (36V) LXT Brushless Lawnmower

DLM530

No Load Speed	2,300 / 2,800 rpm
Cutting Width	534mm
Height Adjustment	20 - 100mm (10-step)
Collection box	70L
Net Weight	35.5 - 39.3kg

**RECOMMENDED FOR LAWNS OF UP TO 2,300 m<sup>2</sup>**

**STEEL DECK**

**4 Batteries for extended run time**  
The mower will use 2 batteries at a time. When the first set goes flat turn the switch and keep mowing.



**Model Versions**

- DLM530PT4 4x 5.0Ah
- DLM530PG2 2x 6.0Ah
- DLM530Z Body Only

STANDARD EQUIPMENT: Fast charger, battery cartridges, Blade, Mulch plug, Side Discharge Mouth, Socket Wrench, Rod

18V x2 (36V) LXT Brushless Lawnmower

DLM532

No Load Speed	2,300 / 2,800 rpm
Cutting Width	534mm
Height Adjustment	20 - 100mm (10-step)
Collection box	70L
Net Weight	39.0 - 42.8kg

**RECOMMENDED FOR LAWNS OF UP TO 2,300m<sup>2</sup>**

**STEEL DECK**

**4 Batteries for extended run time**  
The mower will use 2 batteries at a time. When the first set goes flat turn the switch and keep mowing.



**Model Versions**

- DLM532PT4 4x 5.0Ah
- DLM532PG2 2x 6.0Ah
- DLM532Z Body Only

18V x2 (36V) LXT Brushless Lawnmower

DLM533

No Load Speed	2,300 / 2,800 rpm
Cutting Width	534mm
Height Adjustment	20 - 100mm (10-step)
Collection box	70L
Net Weight	43.9 - 47.9 kg

**RECOMMENDED FOR LAWNS OF UP TO 2,300m<sup>2</sup>**

**ALUMINIUM DECK**



**Model Versions**

- DLM533PT4 4x 5.0Ah
- DLM533PG2 2x 6.0Ah
- DLM533Z Body Only

STANDARD EQUIPMENT: Fast charger, battery cartridges, Blade, Mulch plug, Socket Wrench, Rod

4 X 18V BATTERIES: DLM462/530/532/533

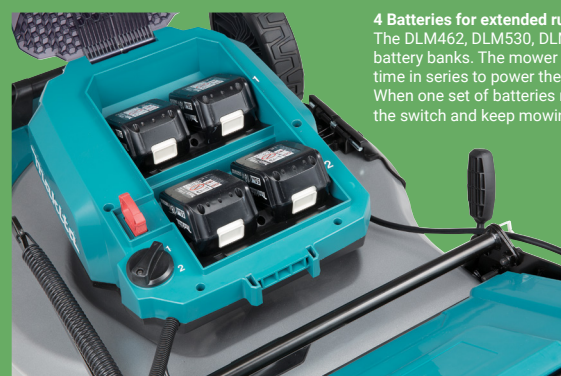

**4 Batteries for extended run time**  
The DLM462, DLM530, DLM532, DLM533 have 2 battery banks. The mower will use 2 batteries at a time in series to power the 36V brushless motor. When one set of batteries run flat then simply turn the switch and keep mowing.



36V Brushless Motor



# LXT CORDLESS

# 64V MAX CORDLESS

## 36V LXT Connect X Brushless Lawnmower

LM001C

No Load Speed	2,800rpm (normal mode)
	2,300-2,800rpm (Soft no load mode)
	2,300 rpm (Low noise mode)
Cutting Width	534mm
Height Adjustment	20-100mm (10-step)
Collection box	70L
Net Weight	42.1-49.5 kg

**APPROX. MOWING AREA WITH PDC1200 IN PUSH MODE: 6900m<sup>2</sup>**

**APPROX. MOWING AREA WITH PDC01 EQUIPPED (4X 6.0AH BATTERIES) IN PUSH MODE: 2300m<sup>2</sup>**



Powered by Back Pack Power Supply Only (see page 7)



**CONNECT X**  
**LXT BL SOFT MOTOR NOLOAD**

**Model Versions**  
LM001CX3 Includes PDC1200A02  
LM001CZ Body Only

STANDARD EQUIPMENT: Blade, mulch plug, side discharge mouth, socket wrench, rod.

## LM001C WITH BACKPACK POWER SUPPLY



**Quick Connect**  
LM001CZ connects straight to the PDC01 or PDC1200 via the standard plug.



The PDC01 or PDC1200 battery level can be checked on the side of each battery pack.



## 64V Max Brushless Lawnmower

LM002JM101

No Load Speed:	2,800 rpm
Standard Mode	2,300-2,800 rpm
Soft No-Load Mode	2,300 rpm
Max output	2,300W
Cutting Width	534mm
Height Adjustment	20 - 100mm (10 stages)
Box Capacity	70L
Net Weight	25.7 - 27.6kg

**RECOMMENDED FOR LAWNS OF UP TO 1,600m<sup>2</sup>**



This product is powered by the BL6440 64V 4.0Ah battery



**SOFT NOLOAD BL MOTOR**

**Model Versions**  
LM002JM101 1x 4.0Ah

STANDARD EQUIPMENT: Fast Charger, battery cartridge

## 64V Max Brushless Lawnmower

LM004JM101

No Load Speed:	2,800 rpm
Standard Mode	2,300 - 2,800 rpm
Soft No-Load Mode	2,300 - 2,800 rpm
Max output	3,200W
Noise reduction mode	2,300 rpm
Cutting Width	534mm
Height Adjustment	20 - 100mm (10 stages)
Box Capacity	70L
Net Weight	31.5 - 34.6 Kg

**ANTI-RESTART FUNCTION**

**STEEL CUTTING DECK**

**RECOMMENDED FOR LAWNS OF UP TO 3,800m<sup>2</sup>**



This product is powered by the BL6440 64V 4.0Ah battery



**SOFT NOLOAD BL MOTOR**

**Model Versions**  
LM004JM101 1x 4.0Ah

STANDARD EQUIPMENT: Standard charger, battery cartridge, rod 6, mulching plug, discharge chute, wrench.

## 64V MAX BATTERY: LM002J & LM004J



**64V Battery and Motor**  
The LM002J & LM004J have a 64V brushless motor powered by the new 64V Max 4.0Ah (BL6440) battery pack.



BL6440

DC64WA

**Electric Chainsaw** UC3541A/2 UC4041A/2

Input wattage	1,800W	<b>AUTOMATIC CHAIN OILING TOOL-LESS BLADE CHANGE</b>
Chain speed	14.5m/s	
Pitch, chain gauge	3/8", 0.050"	
Chain oil tank capacity	200ml	
Net weight	UC3541A: 4.7-4.8kg UC4041A: 4.8-4.9kg	



**Model Versions**  
**UC3541A/2** 35cm Bar 240V  
**UC4041A/2** 40cm Bar 240V

STANDARD EQUIPMENT: Guide bar, chain, chain protection cover, hook complete.

**Electric Chainsaw** UC3551A UC4051A

Input wattage 110V	1,570W	<b>AUTOMATIC CHAIN OILING TOOL-LESS BLADE CHANGE</b>
Input wattage 240V	2,000W	
Chain speed	14.5m/s	
Pitch, chain gauge	3/8", 0.050"	
Chain oil tank capacity	200ml	
Net weight	5.4-5.7kg	



**Model Versions**  
**UC3551A/2** 35cm Bar 240V  
**UC4051A/1** 40cm Bar 110V  
**UC4051A/2** 40cm Bar 240V

STANDARD EQUIPMENT: Guide bar, chain, chain protection cover, hook complete.

**Electric Linetrimmer** UR3501 **Electric Linetrimmer** UR3000

Cutting Width	350mm
Input Wattage	1,000W
No Load Speed	7,500rpm
Nylon Cord Diameter	2.0mm
Net Weight	4.3kg

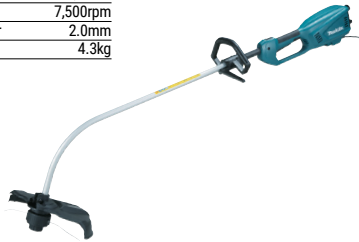

**Model Versions**  
**UR3501/2**

STANDARD EQUIPMENT: Nylon cutting head, harness, socket wrench.

Input wattage	450W
Cutting diameter	300mm
No load speed	9,000rpm
Net weight	2.6kg



**Model Versions**  
**UR3000/2**

STANDARD EQUIPMENT: Shoulder strap, spool assembly, safety glasses.

**Electric Hedge Trimmer** UH5580/6580 /7580

	UH5580	UH6580	UH7580
Input wattage	670W	670W	670W
Blade length	55cm	65cm	75cm
Max. branch Ø	18mm	18mm	18mm
Net weight	4.2kg	4.3kg	4.4kg



**Model Versions**  
**UH5580/2**  
**UH6580/2**  
**UH7580/2**

STANDARD EQUIPMENT: Blade cover, cord hook for waist belt, 10m lead.

**Electric Hedge Trimmer** UH4570/5570 /6570

	UH4570	UH5570	UH6570
Input wattage	550W	550W	550W
Blade length	45cm	55cm	65cm
Max. branch Ø	18mm	18mm	18mm
Net weight	3.6kg	3.7-3.8kg	3.8-3.9kg



**Model Versions**  
**UH4570/2**  
**UH5570/2**  
**UH6570/2**

STANDARD EQUIPMENT: Blade cover, cord hook for waist belt, 10m lead.

**Electric Lawnmower** ELM4121X

Input Wattage	1,600W
No Load Speed	3,400rpm
Cutting Width	41cm
Cutting Heights	7 settings (20-75mm)
Collection Box	50 litres
Net Weight	17.5-19.1kg

**RECOMMENDED FOR LAWNS  
OF UP TO 600Sm<sup>2</sup>**

**STEEL DECK**



**Model Versions**  
**ELM4121X**

STANDARD EQUIPMENT: Wrench, mulch plug.





**Electric Lawnmower**

ELM4621X

Input Wattage	1,800W
No Load Speed	2,950rpm
Cutting Width	46cm
Cutting Heights	8 settings (20-75mm)
Collection Box	60 litres
Net Weight	30.5-32.2kg

**RECOMMENDED FOR LAWNS  
OF UP TO 1000m<sup>2</sup>**

**STEEL DECK**



**Model Versions**

**ELM4621X**

STANDARD EQUIPMENT: Wrench, mulch plug.



**Electric Scarifier**

UV3200

Rated voltage	230-240v~50-60Hz
Rated power	1300W
No load speed	3500/min
Working width	32cm
Working depth	-10~+10mm
Height adjustment	5 settings
Collection container capacity	30 litres
Net weight	12.0kg

**CAN BE USED WITH OR WITHOUT  
COLLECTION BOX**



**Model Versions**

**UV3200/2**

STANDARD EQUIPMENT: 10m power lead.



**Electric Lawnmower**

ELM3320X

Input Wattage	1,200W
No Load Speed	3,400rpm
Cutting Width	33cm
Cutting Heights	(3-settings)
	20 - 55mm
Collection Box	30L
Net Weight	10.2kg

**RECOMMENDED FOR LAWNS  
OF UP TO 400m<sup>2</sup>**



**Model Versions**

**ELM3320X**

STANDARD EQUIPMENT: Wrench.



**Electric Scarifier**

UV3600

Rated voltage	230-240v~50-60Hz
Rated power	1800W
No load speed	3700/min
Working width	36cm
Working depth	-10~+5mm
Height adjustment	4 settings
Collection container capacity	40 litres
Net weight	15.3kg

**CAN BE USED WITH OR WITHOUT  
COLLECTION BOX**



**Model Versions**

**UV3600/2**

STANDARD EQUIPMENT: 10m power lead.



**Electric Lawnmower**

ELM3720X

Input Wattage	1,400W
No Load Speed	3,400rpm
Cutting Width	37cm
Cutting Heights	(3-settings)
	20 - 55mm
Collection Box	40L
Net Weight	11.6kg

**RECOMMENDED FOR LAWNS  
OF UP TO 500m<sup>2</sup>**



**Model Versions**

**ELM3720X**

STANDARD EQUIPMENT: Wrench.



**Electric Shredder**

UD2500/2

Input wattage	2,500W
Max. branch Ø	45 mm
Cutting speed	40 rpm
Collection box capacity	67 litres
Net weight	27.6kg



**Model Versions**

**UD2500/2**

STANDARD EQUIPMENT: 10m power lead.

